

## STANDARD

LMC's cardan couplings are heavy duty quick couplings used in agricultural, irrigation, cleaning and construction applications. They are most commonly used with systems carrying water, mortar, bitumen, bulk products, etc.

## OPERATION

Cardan couplings consist of a male and a female section. The female section incorporates a thick o-ring seal and a lever-operated 2-claw latch. The male section is inserted into the female section and the joint closed by latching the lever over the conical head of the male section. The seal between the male and female section enables the cardan coupling to remain secure up to 15° deflection.

LMC's Cardan couplings hose shanks are designed to be used in heavy applications. This feature makes LMC's Cardan couplings more resistant to impact and wear, ensuring a longer working life.

N.B.: Cardan couplings are not interchangeable with Bauer couplings.

## FEATURES



1. Specially designed serrated hose shank for a perfect binding assembly using band clamps and safety clamps
2. Extra-thick wall for longer working life
3. Thick SBR o-ring seal for a guaranteed total seal in pressure and vacuum applications
4. Deflection up to 30° when closed (-15°/+15° axis)
5. Easy single handed closure

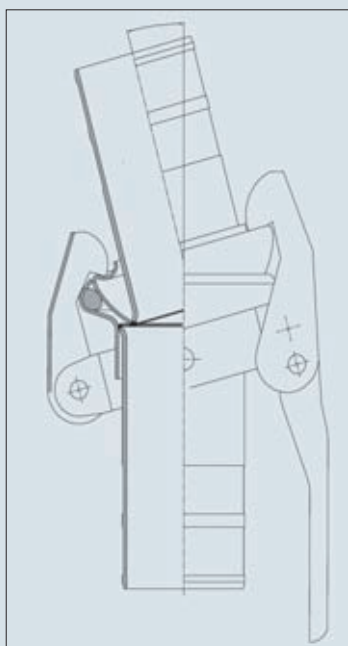

## DIMENSIONS

ND	A MM	B MM	C MM	D MM	E MM	F MM
50	230.0	128.0	85.0	76.0	51.0	2.60
70	270.0	163.0	108.0	103.0	63.0	3.60
89	310.0	194.0	136.0	133.0	76.1	2.90
108	360.0	232.0	161.0	154.0	101.6	3.60
133	370.0	264.0	188.0	179.0	127.0	4.00
159	370.0	313.0	223.0	210.0	152.4	4.00

Dimensions are given as illustration only

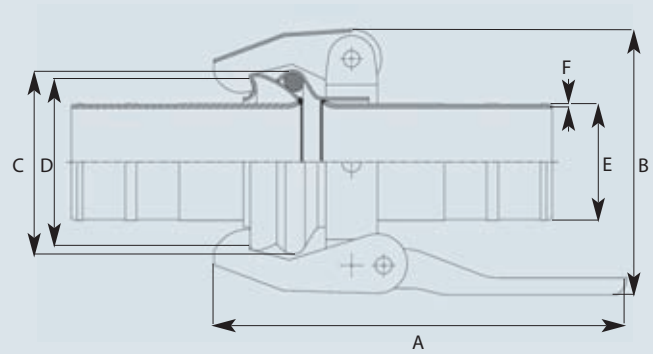

## APPLICATION

- Emptying tanks and reservoirs containing environmentally harmful waste products
- Transporting bulk products, such as grain, flour, feed, pellets, granulates, concrete and minerals
- Transporting water
- Pressure and suction connections to pumps

## WORKING PRESSURE

ND	BAR	PSI
50	20	290
70	20	290
89	15	217
108	15	217
133	10	145
159	10	145



## TEMPERATURE

-40°C / -40°F up to +80°C / +176°F

Hose, coupling, assembly method and seal must be chosen in relation with the desired application and temperature range.

## MATERIAL

- Coupling
  - Galvanized carbon steel St 37-2 (female section with steel lever)
  - Stainless steel AISI 304 - EN 1.4301 (female section with steel lever)
- Seal
  - SBR
  - NBR, EPDM on request

## ASSEMBLY

Band, bolt clamps

RK safety clamps to EN 14420-3 / DIN 2817

FLEXOLINE® safety clamp

Welding

A.9.2

# CARDAN COUPLINGS



## MALE HEAVY DUTY COUPLING WITH SERRATED HOSE SHANK

ND	For hose mm	Material	Weight/pc Kg	Reference
50	50	Carbon steel	0.48	KVS050
70	63	Carbon steel	0.88	KVS063
89	75	Carbon steel	1.62	KVS075
108	100	Carbon steel	2.19	KVS100
133	125	Carbon steel	3.62	KVS125
159	150	Carbon steel	4.30	KVS150
50	50	Stainless steel	0.45	RKVS050
70	63	Stainless steel	0.83	RKVS063
89	75	Stainless steel	1.57	RKVS075
108	100	Stainless steel	2.10	RKVS100
133	125	Stainless steel	3.50	RKVS125
159	150	Stainless steel	4.12	RKVS150



Galvanized carbon steel  
Stainless steel AISI 304 - EN 1.4301  
Assembly: band or bolt clamps

## FEMALE HEAVY DUTY COUPLING WITH SERRATED HOSE SHANK

ND	For hose mm	Material	Weight/pc Kg	Reference
50	50	Carbon steel	1.13	KMS050
70	63	Carbon steel	1.89	KMS063
89	75	Carbon steel	3.19	KMS075
108	100	Carbon steel	5.06	KMS100
133	125	Carbon steel	8.01	KMS125
159	150	Carbon steel	9.11	KMS150
50	50	Stainless steel	1.07	RKMS050
70	63	Stainless steel	1.77	RKMS063
89	75	Stainless steel	3.05	RKMS075
108	100	Stainless steel	4.92	RKMS100
133	125	Stainless steel	7.91	RKMS125
159	150	Stainless steel	9.00	RKMS150



Galvanized carbon steel  
Stainless steel AISI 304 - EN 1.4301  
Stainless steel coupling: lever in galvanized carbon steel  
Assembly: band or bolt clamps

# CARDAN COUPLINGS



## MALE HEAVY DUTY CARDAN COUPLING WITH SMOOTH HOSE SHANK

ND	For hose mm	Material	Weight/pc Kg	Reference
50	50	Carbon steel	0.54	KVSK050
70	63	Carbon steel	1.02	KVSK063
89	75	Carbon steel	1.42	KVSK075
108	100	Carbon steel	2.49	KVSK100
133	125	Carbon steel	4.39	KVSK125
159	150	Carbon steel	5.09	KVSK150
50	50	Stainless steel	0.50	RKVK050
70	63	Stainless steel	0.92	RKVK063
89	75	Stainless steel	1.30	RKVK075
108	100	Stainless steel	2.35	RKVK100
133	125	Stainless steel	4.12	RKVK125
159	150	Stainless steel	5.01	RKVK150



Galvanized carbon steel  
 Stainless steel AISI 304 - EN 1.4301  
 Assembly: RK safety clamps complying with EN 14420-3 / DIN 2817  
 FLEXOLINE® safety clamps

## FEMALE HEAVY DUTY CARDAN COUPLING WITH SMOOTH HOSE SHANK

ND	For hose mm	Material	Weight/pc Kg	Reference
50	50	Carbon steel	1.21	KMSK050
70	63	Carbon steel	2.75	KMSK063
89	75	Carbon steel	3.15	KMSK075
108	100	Carbon steel	5.66	KMSK100
133	125	Carbon steel	7.82	KMSK125
159	150	Carbon steel	10.04	KMSK150
50	50	Stainless steel	1.15	RKMSK050
70	63	Stainless steel	2.60	RKMSK063
89	75	Stainless steel	3.01	RKMSK075
108	100	Stainless steel	5.55	RKMSK100
133	125	Stainless steel	7.65	RKMSK125
159	150	Stainless steel	10.00	RKMSK150



Galvanized carbon steel  
 Stainless steel AISI 304 - EN 1.4301  
 Stainless steel coupling: lever in galvanized carbon steel  
 Assembly: RK safety clamps complying with EN 14420-3 / DIN 2817  
 FLEXOLINE® safety clamps

# CARDAN COUPLINGS



## MALE WELDING PART

ND	For tube mm	Material	Weight/pc Kg	Reference
50	51.0	Carbon steel	0.12	KVRK050
70	70.0	Carbon steel	0.27	KVRK070
89	89.0	Carbon steel	0.42	KVRK089
108	108.0	Carbon steel	0.63	KVRK108
133	133.0	Carbon steel	0.81	KVRK133
159	159.0	Carbon steel	1.28	KVRK159
50	51.0	Stainless steel	0.10	RKVRK050
70	70.0	Stainless steel	0.23	RKVRK070
89	89.0	Stainless steel	0.36	RKVRK089
108	108.0	Stainless steel	0.55	RKVRK108
133	133.0	Stainless steel	0.76	RKVRK133
159	159.0	Stainless steel	1.22	RKVRK159



Non-galvanized carbon steel  
Stainless steel AISI 304 - EN 1.4301  
Assembly: Welding

## FEMALE WELDING PART

ND	For tube mm	Material	Weight/pc Kg	Reference
50	51.0	Carbon steel	0.76	KMRK050
70	70.0	Carbon steel	1.46	KMRK070
89	89.0	Carbon steel	1.79	KMRK089
108	108.0	Carbon steel	3.40	KMRK108
133	133.0	Carbon steel	5.14	KMRK133
159	159.0	Carbon steel	6.03	KMRK159
50	51.0	Stainless steel	0.74	RKMRK050
70	70.0	Stainless steel	1.36	RKMRK070
89	89.0	Stainless steel	1.65	RKMRK089
108	108.0	Stainless steel	3.25	RKMRK108
133	133.0	Stainless steel	5.06	RKMRK133
159	159.0	Stainless steel	5.95	RKMRK159



Non-galvanized carbon steel  
Stainless steel AISI 304 - EN 1.4301  
Stainless steel coupling: lever in galvanized carbon steel  
Assembly: Welding

# CARDAN COUPLINGS



## MALE PLUG

ND	Material	Weight/pc Kg	Reference
50	Carbon steel	0.30	KKV050
70	Carbon steel	0.42	KKV063
89	Carbon steel	0.55	KKV075
108	Carbon steel	0.86	KKV100
133	Carbon steel	1.19	KKV125
159	Carbon steel	1.70	KKV150
50	Stainless steel	0.25	RKKV050
70	Stainless steel	0.39	RKKV063
89	Stainless steel	0.50	RKKV075
108	Stainless steel	0.79	RKKV100
133	Stainless steel	1.05	RKKV125
159	Stainless steel	1.55	RKKV150



Galvanized carbon steel  
Stainless steel AISI 304 - EN 1.4301

## FEMALE CAP

ND	Material	Weight/pc Kg	Reference
50	Carbon steel	1.82	KKM050
70	Carbon steel	1.53	KKM063
89	Carbon steel	2.15	KKM075
108	Carbon steel	3.65	KKM100
133	Carbon steel	5.49	KKM125
159	Carbon steel	6.68	KKM150
50	Stainless steel	1.69	RKKM050
70	Stainless steel	1.50	RKKM063
89	Stainless steel	2.01	RKKM075
108	Stainless steel	3.45	RKKM100
133	Stainless steel	5.40	RKKM125
159	Stainless steel	6.53	RKKM150



Galvanized carbon steel  
Stainless steel AISI 304 - EN 1.4301  
Stainless steel coupling: lever in galvanized carbon steel

## MALE PART WITH FLANGE IN COMPLIANCE WITH DIN 2633

ND	Material	Weight/pc Kg	Reference
50	Carbon steel	3.07	KF050
70	Carbon steel	3.95	KF070
89	Carbon steel	5.16	KF089
108	Carbon steel	5.84	KF108
133	Carbon steel	7.11	KF133
159	Carbon steel	10.76	KF159



Galvanized carbon steel

# CARDAN COUPLINGS



## FEMALE PART WITH FLANGE IN COMPLIANCE WITH DIN 2633

ND	Material	Weight/pc Kg	Reference
50	Carbon steel	6.07	KE050
70	Carbon steel	8.10	KE070
89	Carbon steel	12.22	KE089
108	Carbon steel	13.51	KE108
133	Carbon steel	16.20	KE133
159	Carbon steel	20.59	KE159

Galvanized carbon steel



## MALE REDUCING COUPLING WITH SERRATED HOSE SHANK

ND	For hose mm	Material	Weight/pc Kg	Reference
108	50	Carbon steel	1.76	KVS050100
89	63	Carbon steel	1.70	KVS063075
108	75	Carbon steel	2.05	KVS075100
89	100	Carbon steel	2.14	KVS100075

Other dimensions and materials on request  
Assembly: band or bolt clamps



## FEMALE REDUCING COUPLING WITH SERRATED HOSE SHANK

ND	For hose mm	Material	Weight/pc Kg	Reference
108	50	Carbon steel	4.48	KMS050100
108	75	Carbon steel	4.69	KMS075100
89	100	Carbon steel	5.01	KMS100075
108	150	Carbon steel	5.80	KMS150100
133	150	Carbon steel	6.55	KMS150125

Other dimensions and materials on request  
Assembly: band or bolt clamps



# CARDAN COUPLINGS



## O-RING SEAL SBR

ND	OD Ø mm	ID Ø mm	Height mm	Material	Weight/pc kg	Reference
50	86.0	64.0	11.0	SBR	0.03	KX050
70	110.0	87.0	11.5	SBR	0.04	KX063
89	140.0	112.0	14.0	SBR	0.08	KX075
108	160.0	124.0	18.0	SBR	0.15	KX100
133	190.0	146.0	22.0	SBR	0.27	KX125
159	220.0	180.0	20.0	SBR	0.26	KX150



SBR = Styrene Butadiene Rubber  
NBR, EPDM on request

Other Cardan couplings on request available



Male-male reversing coupling  
Type: KDVT...



Female-female reversing coupling  
Type: KDMT...



Female-male reversing coupling  
Type: KGMKV...

