

STANDARD

Food couplings complying with DIN 11851 are used in the food, chemical and pharmaceutical industries to connect rubber food hoses and stainless steel pipes (in compliance with DIN 11850).

On request food couplings complying with DIN 11864 available.

OPERATION

The seal must be inserted correctly into the seal sitting of the male coupling before connection. The conical female coupling is then pushed onto the male threaded coupling. The two are secured by sliding the nut across the conical head of the female coupling and onto the thread of the male coupling. The flanged seal enables easy assembly and prevents any displacement by vacuum or pressure.

Threaded food couplings complying with DIN 11851 have a rounded thread complying with DIN 405/1. This rounded thread ensures that DIN 11851 compliant food couplings are easy to connect by hand or using a wrench.

FEATURES

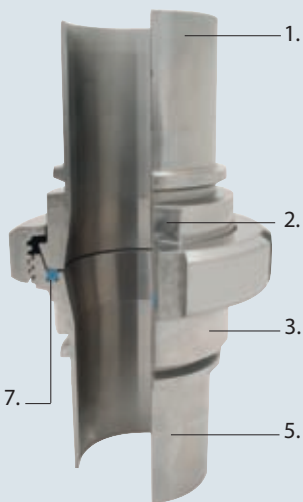

1. Electro-polished external surface for improved hygiene
2. Wrench surface to prevent twisting of the hose when fitting one half of the coupling to the other half.
3. Extra-long head for easy assembly and disassembly
4. Low Ra-value up to $\leq 1.6 \mu\text{m}$
5. Hose shank for assembly with RK safety clamps, or FLEXOLINE[®] safety clamps or HHRK or HRP swage ferrules
6. Easy assembly of protection ring
7. Standard NBR seal conforming FDA directive and ADI-free



CONNECTION

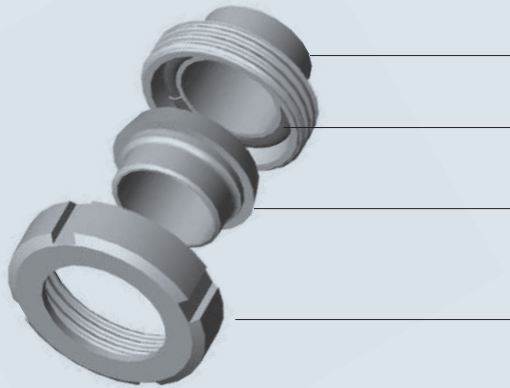

1. Male threaded welding coupling type DIN213...
2. NBR seal type DIN211...
3. Female welding coupling type DIN214...
4. Nut type DIN210...

Food couplings complying with DIN 11851 vs SMS

	DIN 11851	SMS
Female coupling	Conical face	Flat face
Male coupling	Deep seal	Turned-up seal
Seal	U-shape seal	Square seal
Male and female thread	Rounded thread complying with DIN 405/1	Rounded thread complying with DIN 405/1
Max. working pressure	40 bar / 580 psi	6 bar / 87 psi

DIN 11851



SMS



APPLICATION

For the food, beverage, pharmaceutical and chemical industries.

WORKING PRESSURE

ND	BAR	PSI
15	40	580
20	40	580
25	40	580
32	40	580
38	40	580
40	40	580
50	25	362
63	25	362
65	25	362
75	25	362
80	25	362
100	25	362

Working pressure of the coupling must be chosen in relation with the working pressure of the desired hose and pipe.

TEMPERATURE

-30°C / -22°F up to 120°C / 248°F

Hose, coupling, assembly method and seal must be chosen in relation with the disired temperature and working pressure.

MATERIAL

- Coupling
 - Stainless steel AISI 316 - EN 1.4401 = hose coupling (standard)
 - Stainless steel AISI 304 - EN 1.4301 = nut, cap and welding coupling (standard)
- Seal
 - NBR (standard);
 - EPDM;
 - FPM;
 - H-NBR, available on request

ASSEMBLY

1. RK safety clamps complying with EN 14420-3 / DIN 2817
2. FLEXOLINE[®] safety clamps
3. HRRK or HRP swage ferrules
4. Welding

THREADS

Food couplings complying with DIN 11851 are not interchangeable with SMS food couplings. Although the threads of both couplings comply with DIN 405/1, precise dimensions vary, making them non-interchangeable.

ND	THREAD COMPLYING WITH DIN 405/1
15	RD 34 x 1/8"
20	RD 44 x 1/6"
25	RD 52 x 1/6"
32	RD 58 x 1/6"
38	RD 65 x 1/6"
40	RD 65 x 1/6"
50	RD 78 x 1/6"
63	RD 95 x 1/6"
65	RD 95 x 1/6"
75*	RD 104 x 1/6"
80	RD 110 x 1/4"
100	RD 130 x 1/4"

* on request



RA-VALUE

Roughness average value (Ra-value) DIN 11851 couplings

1. Ra-value inner side ≤ 1.6 µm
2. Ra-value outer side ≤ 3.2 µm

Other Ra-values and Ra-report available on request.

FOOD COUPLINGS DIN 11851



FEMALE COUPLING WITH SMOOTH HOSE SHANK AND NUT

ND	Inch	For hose mm	Thread nut DIN 405/1	Weight/pc Kg	Reference
15	1/2"	13	RD 34 x 1/8"	0.22	DKV013
20	3/4"	19	RD 44 x 1/6"	0.28	DKV019
25	1"	25	RD 52 x 1/6"	0.37	DKV025
32	1.1/4"	32	RD 58 x 1/6"	0.44	DKV032
38	1.1/2"	38	RD 65 x 1/6"	0.55	DKV038
40	1.1/2"	40	RD 65 x 1/6"	0.67	DKV040*
50	2"	50	RD 78 x 1/6"	0.76	DKV050
63	2.1/2"	63	RD 95 x 1/6"	1.40	DKV063
65	2.1/2"	65	RD 95 x 1/6"	1.46	DKV065*
80	3"	75	RD 110 x 1/4"	1.89	DKV075
80	3"	80	RD 110 x 1/4"	2.10	DKV080*
100	4"	100	RD 130 x 1/4"	2.89	DKV100



Hose shank standard: EN 14420-2 / DIN 2817

Coupling material: stainless steel AISI 316 - EN 1.4401

Nut material: stainless steel AISI 304 - EN 1.4301

Assembly: RK safety clamps EN 14420-3 / DIN 2817 or FLEXOLINE® safety clamps

*on request

FEMALE COUPLING WITH SERRATED HOSE SHANK AND NUT

ND	Inch	For hose mm	Thread nut DIN 405/1	Weight/pc Kg	Reference
15	1/2"	13	RD 34 x 1/8"	0.14	DKVR013
20	3/4"	19	RD 44 x 1/6"	0.23	DKVR019
25	1"	25	RD 52 x 1/6"	0.34	DKVR025
32	1.1/4"	32	RD 58 x 1/6"	0.44	DKVR032
38	1.1/2"	38	RD 65 x 1/6"	0.56	DKVR038
40	1.1/2"	40	RD 65 x 1/6"	0.63	DKVR040*
50	2"	50	RD 78 x 1/6"	0.81	DKVR050
63	2.1/2"	63	RD 95 x 1/6"	1.34	DKVR063
65	2.1/2"	65	RD 95 x 1/6"	1.37	DKVR065*
80	3"	75	RD 110 x 1/4"	1.62	DKVR075
80	3"	80	RD 110 x 1/4"	2.27	DKVR080*
100	4"	100	RD 130 x 1/4"	2.91	DKVR100



Coupling material: stainless steel AISI 316 - EN 1.4401

Nut material: stainless steel AISI 304 - EN 1.4301

Assembly: HRRK swage ferrules

*on request

FOOD COUPLINGS DIN 11851



FEMALE COUPLING WITH SMOOTH HOSE SHANK WITHOUT NUT

ND	Inch	For hose mm	Weight/pc Kg	Reference
15	1/2"	13	0.13	DKVS013
20	3/4"	19	0.15	DKVS019
25	1"	25	0.20	DKVS025
32	1.1/4"	32	0.24	DKVS032
38	1.1/2"	38	0.31	DKVS038
40	1.1/2"	40	0.36	DKVS040*
50	2"	50	0.48	DKVS050
63	2.1/2"	63	0.48	DKVS063
65	2.1/2"	65	0.90	DKVS065*
75	3"	75	1.15	DKVS075
80	3"	80	1.32	DKVS080*
100	4"	100	1.88	DKVS100



Hose shank standard: EN 14420-2 / DIN 2817

Coupling material: stainless steel AISI 316 - EN 1.4401

Assembly: RK safety clamps EN 14420-3 / DIN 2817 or FLEXOLINE® safety clamps

*on request

FEMALE COUPLING WITH SERRATED HOSE SHANK WITHOUT NUT

ND	Inch	For hose mm	Weight/pc Kg	Reference
15	1/2"	13	0.05	DKVSR013
20	3/4"	19	0.10	DKVSR019
25	1"	25	0.17	DKVSR025
32	1.1/4"	32	0.24	DKVSR032
38	1.1/2"	38	0.32	DKVSR038
40	1.1/2"	40	0.35	DKVSR040*
50	2"	50	0.47	DKVSR050
63	2.1/2"	63	0.78	DKVSR063
65	2.1/2"	65	0.81	DKVSR065*
75	3"	75	1.08	DKVSR075
80	3"	80	1.49	DKVSR080*
100	4"	100	1.90	DKVSR100



Coupling material: stainless steel AISI 316 - EN 1.4401

Assembly: HRRK swage ferrules

*on request

FOOD COUPLINGS DIN 11851



MALE COUPLING WITH SMOOTH HOSE SHANK

ND	Inch	For hose mm	Thread DIN 405/1	Weight/pc Kg	Reference
15	1/2"	13	RD 34 x 1/8"	0.10	DKM013
20	3/4"	19	RD 44 x 1/6"	0.14	DKM019
25	1"	25	RD 52 x 1/6"	0.24	DKM025
32	1.1/4"	32	RD 58 x 1/6"	0.32	DKM032
38	1.1/2"	38	RD 65 x 1/6"	0.38	DKM038
40	1.1/2"	40	RD 65 x 1/6"	0.40	DKM040*
50	2"	50	RD 78 x 1/6"	0.41	DKM050
63	2.1/2"	63	RD 95 x 1/6"	0.89	DKM063
65	2.1/2"	65	RD 95 x 1/6"	0.91	DKM065*
80	3"	75	RD 110 x 1/4"	1.35	DKM075
80	3"	80	RD 110 x 1/4"	1.43	DKM080*
100	4"	100	RD 130 x 1/4"	1.84	DKM100



Hose shank standard: EN 14420-2 / DIN 2817
 Coupling material: stainless steel AISI 316 - EN 1.4401
 Assembly: RK safety clamps EN 14420-3 / DIN 2817
 Seal: NBR blue included
 *on request

MALE COUPLING WITH SERRATED HOSE SHANK

ND	Inch	For hose mm	Thread DIN 405/1	Weight/pc Kg	Reference
15	1/2"	13	RD 34 x 1/8"	0.11	DKMR013
20	3/4"	19	RD 44 x 1/6"	0.19	DKMR019
25	1"	25	RD 52 x 1/6"	0.23	DKMR025
32	1.1/4"	32	RD 58 x 1/6"	0.28	DKMR032
38	1.1/2"	38	RD 65 x 1/6"	0.36	DKMR038
40	1.1/2"	40	RD 65 x 1/6"	0.40	DKMR040*
50	2"	50	RD 78 x 1/6"	0.51	DKMR050
63	2.1/2"	63	RD 95 x 1/6"	1.10	DKMR063
65	2.1/2"	65	RD 95 x 1/6"	1.15	DKMR065*
80	3"	75	RD 110 x 1/4"	1.30	DKMR075
80	3"	80	RD 110 x 1/4"	1.35	DKMR080*
100	4"	100	RD 130 x 1/4"	1.84	DKMR100



Coupling material: stainless steel AISI 316 - EN 1.4401
 Assembly: HRRK swage ferrules
 Seal: NBR blue included
 *on request

FOOD COUPLINGS DIN 11851



NUT

ND	Inch	Thread DIN 405/1	OD Ø mm	ID Ø nut mm	Height mm	Weight/pc kg	Reference
15	1/2"	RD 34 x 1/8"	44.0	25.0	18.0	0.09	DIN210015
20	3/4"	RD 44 x 1/6"	54.0	31.0	20.0	0.13	DIN210020
25	1"	RD 52 x 1/6"	63.0	36.0	21.0	0.17	DIN210025
32	1.1/4"	RD 58 x 1/6"	70.0	42.0	21.0	0.20	DIN210032
40	1.1/2"	RD 65 x 1/6"	78.0	49.0	21.0	0.24	DIN210040
50	2"	RD 78 x 1/6"	92.0	62.0	22.0	0.34	DIN210050
65	2.1/2"	RD 95 x 1/6"	112.0	80.0	25.0	0.56	DIN210065
75	3"	RD 104 x 1/6"	119.0	88.0	25.0	0.74	DIN210075*
80	3"	RD 110 x 1/4"	127.0	94.0	29.0	0.78	DIN210080
100	4"	RD 130 x 1/4"	148.0	115.0	31.0	1.01	DIN210100

Stainless steel AISI 304 - EN 1.4301

Stainless steel AISI 316L - EN 1.4404 on request

* on request



MALE THREADED WELDING COUPLING

ND	Inch	Thread DIN 405/1	OD welding part mm	ID welding part mm	Weight/pc kg	Reference
15	1/2"	RD 34 x 1/8"	21.0	16.0	0.05	DIN213015
20	3/4"	RD 44 x 1/6"	25.0	20.0	0.09	DIN213020
25	1"	RD 52 x 1/6"	31.0	26.0	0.13	DIN213025
32	1.1/4"	RD 58 x 1/6"	37.0	32.0	0.15	DIN213032
40	1.1/2"	RD 65 x 1/6"	43.0	38.0	0.17	DIN213040
50	2"	RD 78 x 1/6"	55.0	50.0	0.17	DIN213050
65	2.1/2"	RD 95 x 1/6"	72.0	66.0	0.40	DIN213065
75	3"	RD 104 x 1/6"	86.0	72.1	0.48	DIN213075*
80	3"	RD 110 x 1/4"	87.0	81.0	0.57	DIN213080
100	4"	RD 130 x 1/4"	106.0	100.0	0.72	DIN213100

Stainless steel AISI 304 - EN 1.4301; Stainless steel AISI 316L - EN 1.4404 on request

Seal not included

* on request



FEMALE WELDING COUPLING

ND	Inch	OD cone part mm	OD welding part mm	ID welding part mm	Weight/pc kg	Reference
15	1/2"	28.0	21.0	16.0	0.03	DIN214015
20	3/4"	36.0	25.0	20.0	0.05	DIN214020
25	1"	44.0	31.0	26.0	0.09	DIN214025
32	1.1/4"	50.0	37.0	32.0	0.12	DIN214032
40	1.1/2"	56.0	43.0	38.0	0.14	DIN214040
50	2"	68.0	55.0	50.0	0.19	DIN214050
65	2.1/2"	86.0	72.0	66.0	0.32	DIN214065
75	3"	93.0	86.0	72.1	0.35	DIN21475*
80	3"	100.0	87.0	81.0	0.39	DIN214080
100	4"	121.0	106.0	100.0	0.62	DIN214100

Stainless steel AISI 304 - EN 1.4301; Stainless steel AISI 316L - EN 1.4404 on request

*on request



FOOD COUPLINGS DIN 11851



MALE PLUG

ND	Inch	Thread DIN 405/1	SW mm	Height mm	Weight/pc kg	Reference
25	1"	RD 52 x 1/6"	27.0	24.0	0.19	DIN217025
32	1.1/4"	RD 58 x 1/6"	27.0	24.0	0.22	DIN217032
40	1.1/2"	RD 65 x 1/6"	27.0	24.0	0.25	DIN217040
50	2"	RD 78 x 1/6"	27.0	24.0	0.35	DIN217050
65	2.1/2"	RD 95 x 1/6"	27.0	28.0	0.64	DIN217065
80	3"	RD 110 x 1/4"	27.0	30.0	1.30	DIN217080
100	4"	RD 130 x 1/4"	27.0	30.0	2.10	DIN217100



Stainless steel AISI 304 - EN 1.4301
Seal not included

FEMALE CAP

ND	Inch	Thread DIN 405/1	OD Ø mm	Height mm	Weight/pc kg	Reference
15	1/2"	RD 34 x 1/8"	44.0	18.0	0.10	DIN220015
20	3/4"	RD 44 x 1/6"	54.0	21.0	0.14	DIN220020
25	1"	RD 52 x 1/6"	63.0	21.0	0.33	DIN220025
32	1.1/4"	RD 58 x 1/6"	70.0	21.0	0.41	DIN220032
40	1.1/2"	RD 65 x 1/6"	78.0	21.0	0.49	DIN220040
50	2"	RD 78 x 1/6"	92.0	22.0	0.71	DIN220050
65	2.1/2"	RD 95 x 1/6"	112.0	25.0	1.24	DIN220065
75	3"	RD 104 x 1/6"	119.0	25.0	1.35	DIN220075*
80	3"	RD 110 x 1/4"	127.0	30.0	1.75	DIN220080
100	4"	RD 130 x 1/4"	148.0	31.0	2.43	DIN220100



Stainless steel AISI 304 - EN 1.4301
Seal type DIN222... not included
* on request available

FEMALE CAP WITH BOSS

ND	Inch	Thread DIN 405/1	OD Ø mm	Height mm	Weight/pc kg	Reference
15	1/2"	RD 34 x 1/8"	44.0	18.0	0.15	DIN221015
20	3/4"	RD 44 x 1/6"	54.0	21.0	0.23	DIN221020
25	1"	RD 52 x 1/6"	63.0	21.0	0.33	DIN221025
32	1.1/4"	RD 58 x 1/6"	70.0	21.0	0.41	DIN221032
40	1.1/2"	RD 65 x 1/6"	78.0	21.0	0.49	DIN221040
50	2"	RD 78 x 1/6"	92.0	22.0	0.71	DIN221050
65	2.1/2"	RD 95 x 1/6"	112.0	25.0	1.24	DIN221065
75	3"	RD 104 x 1/6"	119.0	25.0	1.20	DIN221075*
80	3"	RD 110 x 1/4"	127.0	30.0	1.75	DIN221080
100	4"	RD 130 x 1/4"	148.0	31.0	2.43	DIN221100



Stainless steel AISI 304 - EN 1.4301
Seal type DIN222... not included
* on request available

FOOD COUPLINGS DIN 11851



U-SHAPE SEAL - NBR

ND	Inch	OD Ø mm	ID Ø mm	Height mm	Weight/pc kg	Reference
15	1/2"	26.0	18.0	4.5	0.002	DIN211015
20	3/4"	33.0	23.0	4.5	0.003	DIN211020
25	1"	40.0	30.0	5.0	0.004	DIN211025
32	1.1/4"	46.0	36.0	5.0	0.004	DIN211032
40	1.1/2"	52.0	42.0	5.0	0.005	DIN211040
50	2"	64.0	54.0	5.0	0.006	DIN211050
65	2.1/2"	81.0	71.0	5.0	0.008	DIN211065
75	3"	88.0	78.0	5.0	0.008	DIN211075
80	3"	95.0	85.0	5.0	0.008	DIN211080
100	4"	114.0	104.0	6.0	0.013	DIN211100



NBR blue standard, EPDM, FPM H-NBR and Silicone on request available

CAP SEAL - NBR

ND	Inch	OD Ø mm	Height mm	Weight/pc kg	Reference
15	1/2"	34.0	3.0	0.002	DIN222015
20	3/4"	44.0	3.0	0.003	DIN222020
25	1"	52.0	3.0	0.006	DIN222025
32	1.1/4"	58.0	3.0	0.008	DIN222032
40	1.1/2"	65.0	3.0	0.010	DIN222040
50	2"	78.0	3.0	0.020	DIN222050
65	2.1/2"	95.0	3.0	0.029	DIN222065
75	3"	104.0	3.0	0.035	DIN222075*
80	3"	110.0	3.0	0.044	DIN222080
100	4"	130.0	3.0	0.062	DIN222100



NBR beige standard, other materials on request available
* on request

ACCESSORIES

CHAIN WITH S-HOOK

Length mm	Material	Weight/pc Kg	Reference
200	Stainless steel	0.015	KETR200

